



Supporting multi-function devices in the Linux kernel: a tour of the mfd, regmap and syscon APIs

Alexandre Belloni

Bootlin

alexandre.belloni@bootlin.com



- ▶ Embedded Linux engineer at Bootlin
 - ▶ Embedded Linux **expertise**
 - ▶ **Development**, consulting and training
 - ▶ Strong open-source focus
- ▶ Open-source contributor
 - ▶ Maintainer for the Linux kernel **RTC subsystem**
 - ▶ Co-Maintainer of **kernel support for Atmel ARM processors**
 - ▶ Contributing to **kernel support for Marvell ARM (Berlin) processors**

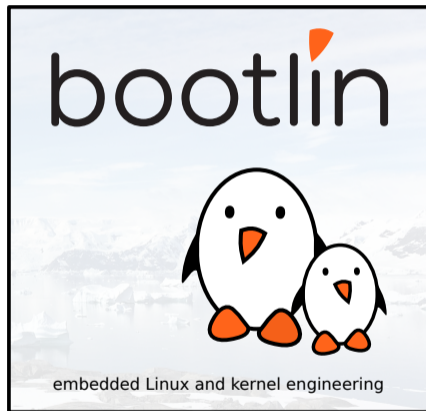



What is a multi-function device ?

- ▶ An external peripheral or a hardware block exposing more than a single functionality
- ▶ Examples:
 - ▶ PMICs
 - ▶ da9063: regulators, led controller, watchdog, rtc, temperature sensor, vibration motor driver, ON key
 - ▶ max77843: regulators, charger, fuel gauge, haptic feedback, LED controller, micro USB interface controller
 - ▶ wm831x: regulator, clocks, rtc, watchdog, touch controller, temperature sensor, backlight controller, status LED controller, GPIOs, ON key, ADC
 - ▶ some even include a codec
 - ▶ atmel-hlcdc: display controller and backlight pwm
 - ▶ Diolan DLN2: USB to I2C, SPI and GPIO controllers
 - ▶ Realtek PCI-E card reader: SD/MMC and memory stick reader
- ▶ The main issue is to register those in different kernel subsystems. In particular the external peripherals are represented by only one `struct device` (or the specialized `i2c_client` or `spi_device`)



MFD subsystem

- ▶ The MFD subsystem has been created to handle those devices
- ▶ Allows to register the same device in multiple subsystems
- ▶ The MFD driver has to multiplex access on the bus (mainly takes care of locking) and handle IRQs
- ▶ May handle clocks
- ▶ May also need to configure the IP
- ▶ May do variant or functions detection
- ▶ Other benefit: allows driver reuse, multiple MFD can reuse drivers from other subsystems.



- ▶ Defined in `include/linux/mfd/core.h`
- ▶ Implemented in `drivers/mfd/mfd-core.c`

```
▶ int mfd_add_devices(struct device *parent, int id,
                    const struct mfd_cell *cells, int n_devs,
                    struct resource *mem_base,
                    int irq_base, struct irq_domain *irq_domain);
```

```
▶ extern void mfd_remove_devices(struct device *parent);
```

- ▶ Also `mfd_add_hotplug_devices`, `mfd_clone_cell`, `mfd_cell_enable`, `mfd_cell_disable` but they are seldom used.



struct mfd_cell

```
struct mfd_cell {
    const char          *name;
    int                 id;
    [...]
    /* platform data passed to the sub devices drivers */
    void                *platform_data;
    size_t              pdata_size;
    /*
     * Device Tree compatible string
     * See: Documentation/devicetree/usage-model.txt Chapter 2.2 for details
     */
    const char          *of_compatible;
    [...]
    /*
     * These resources can be specified relative to the parent device.
     * For accessing hardware you should use resources from the platform dev
     */
    int                 num_resources;
    const struct resource *resources;
    [...]
};
```



Example: tps6507x - registration

```
static const struct i2c_device_id tps6507x_i2c_id[] = {
    { "tps6507x", 0 },
    { }
};
MODULE_DEVICE_TABLE(i2c, tps6507x_i2c_id);

#ifdef CONFIG_OF
static const struct of_device_id tps6507x_of_match[] = {
    {.compatible = "ti,tps6507x", },
    {},
};
MODULE_DEVICE_TABLE(of, tps6507x_of_match);
#endif

static struct i2c_driver tps6507x_i2c_driver = {
    .driver = {
        .name = "tps6507x",
        .of_match_table =
            of_match_ptr(tps6507x_of_match),
    },
    .probe = tps6507x_i2c_probe,
    .remove = tps6507x_i2c_remove,
    .id_table = tps6507x_i2c_id,
};
```

```
static int __init tps6507x_i2c_init(void)
{
    return i2c_add_driver(&tps6507x_i2c_driver);
}
/* init early so consumer devices can complete system boot
subsys_initcall(tps6507x_i2c_init);

static void __exit tps6507x_i2c_exit(void)
{
    i2c_del_driver(&tps6507x_i2c_driver);
}
module_exit(tps6507x_i2c_exit);
```

- ▶ registers as a simple i2c device
- ▶ only oddity `subsys_initcall(tps6507x_i2c_init);` to register early enough



Example: tps6507x - probing

```
static const struct mfd_cell tps6507x_devs[] = {
    {
        .name = "tps6507x-pmic",
    },
    {
        .name = "tps6507x-ts",
    },
};
```

- ▶ tps6507x-pmic in
drivers/regulator/tps6507x-regulator.c
- ▶ tps6507x-ts in
drivers/input/touchscreen/tps6507x-ts.c

```
static int tps6507x_i2c_probe(struct i2c_client *i2c,
                             const struct i2c_device_id *id)
{
    struct tps6507x_dev *tps6507x;
    tps6507x = devm_kzalloc(&i2c->dev, sizeof(struct tps6507x_dev),
                          GFP_KERNEL);
    if (tps6507x == NULL)
        return -ENOMEM;

    i2c_set_clientdata(i2c, tps6507x);
    tps6507x->dev = &i2c->dev;
    tps6507x->i2c_client = i2c;
    tps6507x->read_dev = tps6507x_i2c_read_device;
    tps6507x->write_dev = tps6507x_i2c_write_device;

    return mfd_add_devices(tps6507x->dev, -1, tps6507x_devs,
                          ARRAY_SIZE(tps6507x_devs), NULL, 0, NULL);
}
```



Example: tps6507x - struct tps6507x_dev

```
struct tps6507x_dev {
    struct device *dev;
    struct i2c_client *i2c_client;
    int (*read_dev)(struct tps6507x_dev *tps6507x, char reg, int size,
                    void *dest);
    int (*write_dev)(struct tps6507x_dev *tps6507x, char reg, int size,
                     void *src);
    [...]
};
```

- ▶ Defined in `include/linux/mfd/tps6507x.h`
- ▶ Allows to pass the `i2c_client` and the accessors.
- ▶ `tps6507x.h` also contains the register definitions that can be used in the function drivers.



Example: tps6507x - function drivers

```
static int tps6507x_ts_probe(struct platform_device *pdev)
{
    struct tps6507x_dev *tps6507x_dev = dev_get_drvdata(pdev->dev.parent);
    [...]
};
```

```
static int tps6507x_pmic_probe(struct platform_device *pdev)
{
    struct tps6507x_dev *tps6507x_dev = dev_get_drvdata(pdev->dev.parent);
    [...]
};
```

- ▶ Easy to get the struct tps6507x_dev by using dev.parent



Example: da9063 - registering

```
static struct resource da9063_rtc_resources[] = {
    {
        .name      = "ALARM",
        .start     = DA9063_IRQ_ALARM,
        .end       = DA9063_IRQ_ALARM,
        .flags     = IORESOURCE_IRQ,
    },
    {
        .name      = "TICK",
        .start     = DA9063_IRQ_TICK,
        .end       = DA9063_IRQ_TICK,
        .flags     = IORESOURCE_IRQ,
    }
};

static const struct mfd_cell da9063_devs[] = {
[...],
    {
        .name              = DA9063_DRVNAME_RTC,
        .num_resources     = ARRAY_SIZE(da9063_rtc_resources),
        .resources         = da9063_rtc_resources,
        .of_compatible     = "dlg,da9063-rtc",
    },
[...],
};
```

- ▶ resources are defined like it was done using `platform_data`
- ▶ in that case, they are named for easy retrieval
- ▶ when using `.of_compatible`, the function has to be a child of the MFD (see bindings)



Example: da9063 - drivers/rtc/rtc-da9063.c

```
static int da9063_rtc_probe(struct platform_device *pdev)
{
    [...]

    irq_alarm = platform_get_irq_byname(pdev, "ALARM");
    ret = devm_request_threaded_irq(&pdev->dev, irq_alarm, NULL,
                                   da9063_alarm_event,
                                   IRQF_TRIGGER_LOW | IRQF_ONESHOT,
                                   "ALARM", rtc);

    if (ret) {
        dev_err(&pdev->dev, "Failed to request ALARM IRQ %d: %d\n",
                irq_alarm, ret);
        return ret;
    }

    [...]
};
```

- ▶ Use `platform_get_resource`, `platform_get_resource_byname`, `platform_get_irq`, `platform_get_irq_byname` to retrieve the resources
- ▶ Doesn't even need `dev.parent`, the same driver could be used for an MFD and a standalone chip.



Example: da9063 - DT bindings

```
pmic0: da9063@58 {  
    compatible = "dlg,da9063"  
    reg = <0x58>;  
    interrupt-parent = <&gpio6>;  
    interrupts = <11 IRQ_TYPE_LEVEL_LOW>;  
    interrupt-controller;  
  
    rtc {  
        compatible = "dlg,da9063-rtc";  
    };  
};  
[...]  
};
```



MFD: multiplexing register access

- ▶ A common way of multiplexing access to register sets is to use `regmap`.
- ▶ Create the `regmap` from the MFD driver and pass it down to the children

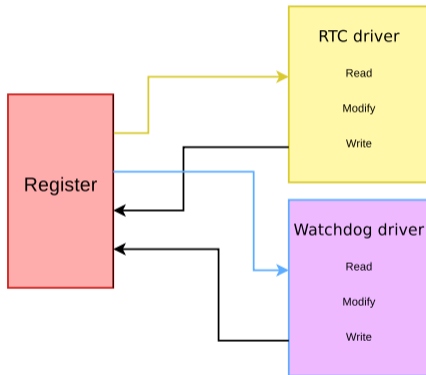

- ▶ has its roots in ASoC (ALSA)
- ▶ can use I2C, SPI and MMIO (also SPMI)
- ▶ actually abstracts the underlying bus
- ▶ can handle locking when necessary
- ▶ can cache registers
- ▶ can handle endianness conversion
- ▶ can handle IRQ chips and IRQs
- ▶ can check register ranges
- ▶ handles read only, write only, volatile, precious registers
- ▶ handles register pages
- ▶ API is defined in `include/linux/regmap.h`
- ▶ implemented in `drivers/base/regmap/`



regmap: creation

- ▶

```
#define regmap_init(dev, bus, bus_context, config)
    __regmap_lockdep_wrapper(__regmap_init, #config,
                             dev, bus, bus_context, config)
```
 - ▶

```
#define regmap_init_i2c(i2c, config)
    __regmap_lockdep_wrapper(__regmap_init_i2c, #config,
                             i2c, config)
```
 - ▶

```
#define regmap_init_spi(dev, config)
    __regmap_lockdep_wrapper(__regmap_init_spi, #config,
                             dev, config)
```
- ▶ Also `devm_` versions
 - ▶ and `_clk` versions



regmap: access

- ▶ `int regmap_read(struct regmap *map, unsigned int reg, unsigned int *val);`
- ▶ `int regmap_write(struct regmap *map, unsigned int reg, unsigned int val);`
- ▶ `int regmap_update_bits(struct regmap *map, unsigned int reg,
 unsigned int mask, unsigned int val);`



regmap: cache management

- ▶ `int regcache_sync(struct regmap *map);`
- ▶ `int regcache_sync_region(struct regmap *map, unsigned int min, unsigned int max);`
- ▶ `int regcache_drop_region(struct regmap *map, unsigned int min, unsigned int max);`
- ▶ `void regcache_cache_only(struct regmap *map, bool enable);`
- ▶ `void regcache_cache_bypass(struct regmap *map, bool enable);`
- ▶ `void regcache_mark_dirty(struct regmap *map);`



Example: atmel-hlcdc

include/linux/mfd/atmel-hlcdc.h

```
struct atmel_hlcdc {
    struct regmap *regmap;
    struct clk *periph_clk;
    struct clk *sys_clk;
    struct clk *slow_clk;
    int irq;
};
```

driver/mfd/atmel-hlcdc.c

```
static const struct regmap_config atmel_hlcdc_regmap_config = {
    .reg_bits = 32,
    .val_bits = 32,
    .reg_stride = 4,
    .max_register = ATMEL_HLCD_C_REG_MAX,
    .reg_write = regmap_atmel_hlcdc_reg_write,
    .reg_read = regmap_atmel_hlcdc_reg_read,
    .fast_io = true,
};

static int atmel_hlcdc_probe(struct platform_device *pdev)
{
    struct atmel_hlcdc_regmap *hregmap;
    struct device *dev = &pdev->dev;
    struct atmel_hlcdc *hlcdc;
    struct resource *res;

    [...]

    hlcdc->regmap = devm_regmap_init(dev, NULL, hregmap,
                                    &atmel_hlcdc_regmap_config);

    if (IS_ERR(hlcdc->regmap))
        return PTR_ERR(hlcdc->regmap);

    dev_set_drvdata(dev, hlcdc);

    [...]
}
```



Example: pwm-atmel-hlcdc

```
static int atmel_hlcdc_pwm_probe(struct platform_device *pdev)
{
    const struct of_device_id *match;
    struct device *dev = &pdev->dev;
    struct atmel_hlcdc_pwm *chip;
    struct atmel_hlcdc *hlcdc;
    int ret;

    hlcdc = dev_get_drvdata(dev->parent);
    [...]
    chip->hlcdc = hlcdc;
    [...]
}
```

```
static int atmel_hlcdc_pwm_set_polarity(struct pwm_chip *c,
                                       struct pwm_device *pwm,
                                       enum pwm_polarity polarity)
{
    struct atmel_hlcdc_pwm *chip = to_atmel_hlcdc_pwm(c);
    struct atmel_hlcdc *hlcdc = chip->hlcdc;
    u32 cfg = 0;

    if (polarity == PWM_POLARITY_NORMAL)
        cfg = ATMEL_HLCDC_PWMPOL;

    return regmap_update_bits(hlcdc->regmap, ATMEL_HLCDC_CFG(6),
                              ATMEL_HLCDC_PWMPOL, cfg);
}
```



Example: atmel-flexcom

- ▶ Sometimes an MFD only supports one simultaneous function.
- ▶ The MFD driver only configures the function.

```
static int atmel_flexcom_probe(struct platform_device *pdev)
{
    struct device_node *np = pdev->dev.of_node;
    [...]
    err = of_property_read_u32(np, "atmel,flexcom-mode", &opmode);
    if (err)
        return err;

    if (opmode < ATMEL_FLEXCOM_MODE_USART ||
        opmode > ATMEL_FLEXCOM_MODE_TWI)
        return -EINVAL;
    [...]
    writel(FLEX_MR_OPMODE(opmode), base + FLEX_MR);
    [...]
    return of_platform_populate(np, NULL, NULL, &pdev->dev);
}
```



Example: atmel-flexcom - DT bindings

```
flexcom@f8034000 {
    compatible = "atmel,sama5d2-flexcom";
    reg = <0xf8034000 0x200>;
    clocks = <&flx0_clk>;
    #address-cells = <1>;
    #size-cells = <1>;
    ranges = <0x0 0xf8034000 0x800>;
    atmel,flexcom-mode = <2>;

    spi@400 {
        compatible = "atmel,at91rm9200-spi";
        reg = <0x400 0x200>;
        interrupts = <19 IRQ_TYPE_LEVEL_HIGH 7>;
        pinctrl-names = "default";
        pinctrl-0 = <&pinctrl_flx0_default>;
    };
};
```

- ▶ The SPI driver from 2007 is reused and has not been modified to handle the MFD specifics.

- ▶ Sometimes, a set of registers is used to configure miscellaneous features from otherwise well separated IPs
- ▶ Automatically creates a `regmap` when accessed
- ▶ Defined in `include/linux/mfd/syscon.h`
- ▶ Implemented in `drivers/mfd/syscon.c`



- ▶ `extern struct regmap *syscon_node_to_regmap(struct device_node *np);`
- ▶ `extern struct regmap *syscon_regmap_lookup_by_compatible(const char *s);`
- ▶ `extern struct regmap *syscon_regmap_lookup_by_pdevname(const char *s);`
- ▶ `extern struct regmap *syscon_regmap_lookup_by_phandle(
 struct device_node *np,
 const char *property);`



Example: pinctrl-dove.c

```
static int dove_pinctrl_probe(struct platform_device *pdev)
{
    struct resource *res, *mpp_res;
    struct resource fb_res;
    const struct of_device_id *match =
        of_match_device(dove_pinctrl_of_match, &pdev->dev);
    pdev->dev.platform_data = (void *)match->data;

[...]
```

```
    res = platform_get_resource(pdev, IORESOURCE_MEM, 1);
    if (!res) {
        dev_warn(&pdev->dev, "falling back to hardcoded MPP4 resource\n");
        adjust_resource(&fb_res,
            (mpp_res->start & INT_REGS_MASK) + MPP4_REGS_OFFS, 0x4);
        res = &fb_res;
    }

    mpp4_base = devm_ioremap_resource(&pdev->dev, res);
    if (IS_ERR(mpp4_base))
        return PTR_ERR(mpp4_base);

    res = platform_get_resource(pdev, IORESOURCE_MEM, 2);
    if (!res) {
        dev_warn(&pdev->dev, "falling back to hardcoded PMU resource\n");
        adjust_resource(&fb_res,
            (mpp_res->start & INT_REGS_MASK) + PMU_REGS_OFFS, 0x8);
        res = &fb_res;
    }

    pmu_base = devm_ioremap_resource(&pdev->dev, res);
    if (IS_ERR(pmu_base))
        return PTR_ERR(pmu_base);
```



- ▶ Simple DT binding
- ▶ Documented in `Documentation/devicetree/bindings/mfd/mfd.txt`
- ▶ Implemented in `drivers/of/platform.c`
- ▶ It is actually an alias to `simple-bus`
- ▶ Used in conjunction with `syscon` to create the `regmap`, it allows to avoid writing an MFD driver.



Example: system-timer

arch/arm/boot/dts/at91rm9200.dtsi

```
st: timer@fffffd00 {
    compatible = "atmel,at91rm9200-st", "syscon", "simple-mfd";
    reg = <0xfffffd00 0x100>;
    interrupts = <1 IRQ_TYPE_LEVEL_HIGH 7>;
    clocks = <&slow_xtal>;

    watchdog {
        compatible = "atmel,at91rm9200-wdt";
    };
};
```



Example: system-timer

drivers/clocksource/timer-atmel-st.c

```
static struct regmap *regmap_st;
[...]
```

```
static void __init atmel_st_timer_init(struct device_node *node)
{
    unsigned int val;
    int irq, ret;

    regmap_st = syscon_node_to_regmap(node);
    if (IS_ERR(regmap_st))
        panic(pr_fmt("Unable to get regmap\n"));

    /* Disable all timer interrupts, and clear any pending ones */
    regmap_write(regmap_st, AT91_ST_IDR,
                 AT91_ST_PITS | AT91_ST_WDOVF | AT91_ST_RTTINC | AT91_ST_ALMS);
    regmap_read(regmap_st, AT91_ST_SR, &val);
[...]
```

```
}
CLOCKSOURCE_OF_DECLARE(atmel_st_timer, "atmel,at91rm9200-st",
                       atmel_st_timer_init);
```



Example: system-timer

drivers/watchdog/at91rm9200_wdt.c

```
static struct regmap *regmap_st;
[...]  
static int at91wdt_probe(struct platform_device *pdev)  
{  
    struct device *dev = &pdev->dev;  
    struct device *parent;  
[...]  
    parent = dev->parent;  
    if (!parent) {  
        dev_err(dev, "no parent\n");  
        return -ENODEV;  
    }  
  
    regmap_st = syscon_node_to_regmap(parent->of_node);  
    if (IS_ERR(regmap_st))  
        return -ENODEV;  
[...]  
}
```

Questions?

Alexandre Belloni

`alexandre.belloni@bootlin.com`

Slides under CC-BY-SA 3.0

<http://bootlin.com/pub/conferences/2015/elce/belloni-mfd-regmap-syscon/>